



WE SOLVE THERMAL CHALLENGES



Technics & Industry

Energy Efficiency with Vacuum Insulation Panels

We produce our brochure sustainably:



By producing our brochure in accordance with the provisions of EU Ecolabel, we emphasize our claim for sustainability. The EU Ecolabel is awarded to products and services that have a lower environmental impact

than comparable products. This allows the identification of environmentally friendlier and healthier products and services.

Natural paper from sustainably managed forests

The EU Ecolabel places high demands on the entire manufacturing process, including the paper used. The wood fibers used in the paper come from sustainably managed forests. The product meets strict environmental and usability criteria. Certified regional waste disposal

companies ensure resource-saving waste disposal and responsible wastewater policies.

Low-pollution printing with organic printing inks and varnishes

Our *bonitasprint* print shop uses low-pollution consumables in all printing processes and prints completely alcohol-free. Workflows and processes are constantly optimized in order to make the entire production process as sustainable as possible.

Renewable raw mate-

rials are the basis for organic printing inks and organic varnishes, which are used in our brochure.



Emission-optimized company building & delivery

The *bonitasprint* company building is powered by electricity from 100% renewable energy sources. For this purpose, the company operates its own photovoltaic system. The waste heat

from the printing machines and compressors is used to supply heat to the company building. Additional heating is obtained from climate-neutral natural gas with emission compensation.

bonitasprint has a continuous in-house production chain. The company's own fleet includes electric and natural gas vehicles. This prevents transport-related CO₂ emissions. The climate neutrality of these va-Q-tec printed products is also demonstrated by the "climate-neutral printing" logo.

Please collect used paper for recycling.

Content

About va-Q-tec	4
Our technology	6
Technics & Industry	8
Products	10
va-Q-vip® / va-Q-plus®	12/13
va-Q-pro® / va-Q-steel®	14/15
Systems	16
va-Q-shell® / va-Q-shell pipe®	18/19
Engineering support	20
Technical service	22
Our support for your product development	24
Patented quality assurance	26
Applications	28
Hot water tanks	30
Success story VISSMANN	32
Our system solutions	34
Success story BINDER	36
Piping	38
Piping applications	40
Special applications	46
TEnEff Milestones	50

Efficient energy-saving for a better fu

va-Q-tec AG is a medium-sized high-tech company. Since the company was founded in 2001, its **energy-efficient, space-saving and environmentally friendly Vacuum Insulation Panels (VIPs)** are the key technology used in all innovative insulation solutions. va-Q-tec also develops and sells other products such as **high-performance thermal packaging** and air freight containers as well as **hot and cold storage elements (PCMs)**.



va-Q-tec's efficient technology saves valuable energy in areas that are used everyday such as refrigerators and freezers, buildings, technics & industry, automobiles and aircrafts, and for the temperature-controlled transport of pharmaceutical products.



ture

Key factors that drive us forward:



Thermal energy efficiency
Approximately 60% of primary energy consumption in Germany and other industrial countries is used for thermal purposes.



Globalization of supply chains
Increasing globalization and outsourcing of clinical research and manufacturing creates huge requirements for efficient pharma TempChain packaging.



Product safety and regulation
By 2024, 70% of the world's top-selling pharmaceuticals require strictly temperature-controlled supply chain ("TempChain").



Our technology

va-Q-tec, as a pioneer in the vacuum insulation sector, develops innovative insulation solutions for various industrial applications. The products based on Vacuum Insulation Panels (VIPs) offer a high insulating effect, enormously reduced insulation thickness and a very wide range of sizes and shapes due to their modular design. They are particularly advantageous if there is only little space available for the insulation and, nevertheless, very high thermal insulation is required.

All our products are the result of intensive development work. They offer our customers crucial added-value and provide answers to basic societal demands such as energy efficiency. The high product quality, controlled by the globally unique, patented va-Q-check® system, makes possible the reliable usage of our durable, highly efficient vacuum insulation.

Comparison of insulation material thickness at a U-value of 0.35W/(m²·K):

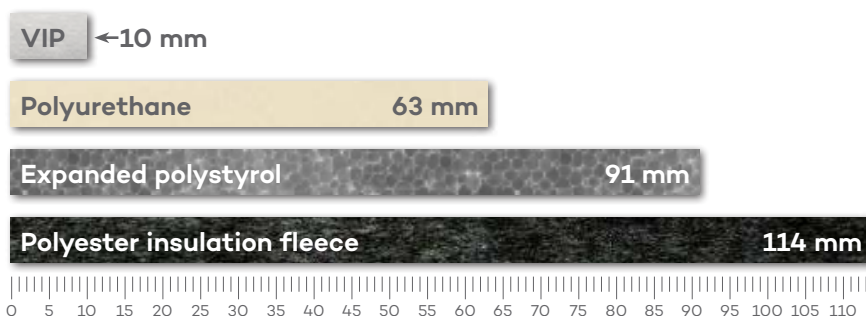



With our technology, we offer our customers energy-efficient and environmentally friendly solutions at the highest level.

Tobias Bock, Head of Business Unit - Technics & Industry / Mobility



Extremely high thermal insulation performance



Cost-efficient solution



Reduction of energy consumption and CO₂ emissions



More usable space due to thin insulation



Durable and manufactured to the highest quality standards, "Made in Germany"



Outstanding functionality and safety



Available in a very wide range of shapes and geometries



Technics & Industry

Since 2001, we have been a pioneer in the area of **high-performance lagging and thermal insulation systems**.

Our products solve thermal challenges. **Due to our flexible technology, we can meet almost all customer requirements.**



As part of our **ISO-certified** processes, 100% of our VIPs are tested using the **va-Q-check®** system.

Our experts **support** our customers during every project phase with their many years of experience.

VIPs offer **ten-times better insulation performance** than conventional insulating materials. That saves space, valuable energy and costs.



The possible applications for our insulation technology are very varied. Vacuum Insulation Panels make it possible to maintain cold and hot temperatures constant, to save space and to reduce energy consumption significantly.



Hot water tanks

Tanks, boilers, heat pumps and more



Industrial installations

Heat shields, enclosures for valves, tanks and more



Pipes

District heating, process heating/cooling, drinking water pipes and more



Laboratory equipment

Freezers, incubators, chromatographs, climatic chambers and more



Ovens and driers

Industrial ovens, climatic cabinets, drying ovens and more



Special applications



Products

- Long service life due to optimised panel designs
- 100% quality control using the patented gas pressure measurement system va-Q-check®
- Sustainable products (recyclable core material)

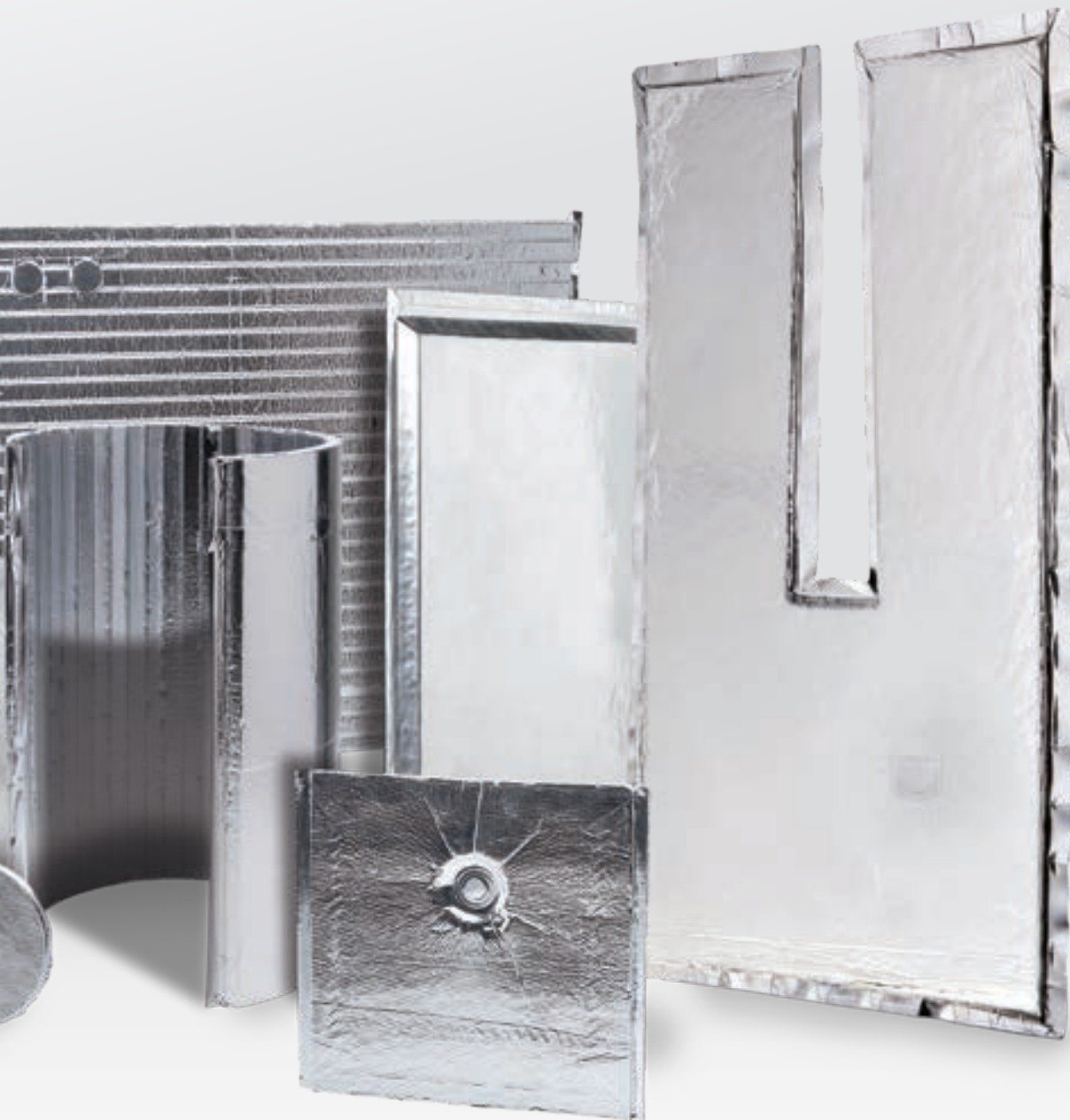

QR code
Scan for more
information





Thermal conductivity ($\lambda_{10\text{ °C}}$): 0.005 W/mK
in accordance with DIN EN 12667



Density:
180 - 210 kg/m³ (thickness > 20 mm)
180 - 250 kg/m³ (thickness ≤ 20 mm)
in accordance with DIN EN 1602



Product dimensions:
(other sizes on request)
Maximum 1,000 x 600 mm
Minimum 100 x 100 mm
Thickness 5 - 50 mm

- Rectangular edges and no foil overlaps due to patented va-Q-seam technology
- Temperature-resistant up to 100 °C, short-term up to 130 °C

va-Q-vip is an evacuated microporous insulating material based on pressed fumed silica powder. va-Q-vip elements are unique due to their rectangular edges and corners (va-Q-seam) whereas individual elements can be connected together almost seamlessly. Rectangular panels are the standard, other shapes such as trapezoid, triangular panels and corner cut-outs are available on request. The compressed core material ensures the excellent insulation performance over the entire service life of the product. Typical applications are, e.g., technical appliances, pharmaceutical containers and the laboratory sector.



Thermal conductivity ($\lambda_{10\text{ °C}}$): 0.0035 W/mK
in accordance with DIN EN 12667



Density: 160 - 230 kg/m³
in accordance with DIN EN 1602



Product dimensions: Maximum 1,800 x 1,100 mm
Minimum 325 x 175 mm
Thickness 6 - 35 mm
(other sizes on request)

- **Very good price/performance ratio**
- **Temperature-resistant up to 100 °C, short-term up to 130 °C**
- **Optional imprinting of rills enables an extremely high flexibility**

va-Q-plus is an evacuated microporous insulating material based on pyrogenic silica. The high-tech panel is manufactured on production lines developed in-house. The powder core material and the specially developed foil technology are designed for good flexibility and an optimal price/performance ratio; they also ensure excellent insulation ability over the entire service life of the product. Typical applications are hot water tanks, district heating pipes, laboratory equipment and the refrigerated trucks and trailer sector.



Thermal conductivity ($\lambda_{10\text{ °C}}$): 0.0035 W/mK
in accordance with DIN EN 12667



Density: 165 - 230 kg/m³
in accordance with DIN EN 1602



Product dimensions: Maximum 1,800 x 1,020 mm
(other sizes on request) Minimum 150 x 150 mm
Thickness 4 - 16 mm

- **Highest flexibility in shape and appearance (3D panel, cut-outs, folded shapes, etc.)**
- **Advanced VIP for demanding installation applications**
- **Temperature-resistant up to 100 °C, short-term 130 °C**

va-Q-pro is an advancement of the va-Q-plus Vacuum Insulation Panel and therefore our most advanced VIP based on fumed silica powder. Our va-Q-pro, which is produced in a fully automated production process, can be produced in various shapes and forms without any additional processes. Along with the standard flat panels, the va-Q-pro can be produced in three-dimensional shapes, in foldable boxes, in shapes with cut-outs and in other configurations. Due to its flexibility of shape, va-Q-pro can be used in various application areas, e.g. for insulating electrical batteries and other automotive parts, for insulating airplane walls, in refrigerators and hot water tanks.



**Thermal conductivity ($\lambda_{10\text{ °C}}$): $\leq 0.0045 - 0.006\text{ W/mK}$
**Thermal conductivity ($\lambda_{200\text{ °C}}$): $\leq 0.008\text{ W/mK}$
in accordance with DIN EN 12667****



Density: **300 - 420 kg/m³**
in accordance with DIN EN 1602



Product dimensions: **Maximum 1,000 x 500 mm**
Minimum 100 x 100 mm
Thickness 10 - 20 mm
(other sizes on request)

- **Application temperature range from -196 °C to +400 °C**
- **All materials used are non-flammable**
- **Almost no ageing effect due to extremely low air and water vapour permeability**

va-Q-steel, the latest development of Vacuum Insulation Panels, is a panel based on an evacuated core material (e.g. pyrogenic silica or glass fibre) for applications with extremely low and extremely high temperatures. The va-Q-steel panel is manufactured using a completely new, unique production process. The stainless steel foil used offers enormous advantages in relation to the mechanical properties and ensures excellent performance over the entire service life. va-Q-steel consists of non-flammable materials and can achieve fire protection classification A.

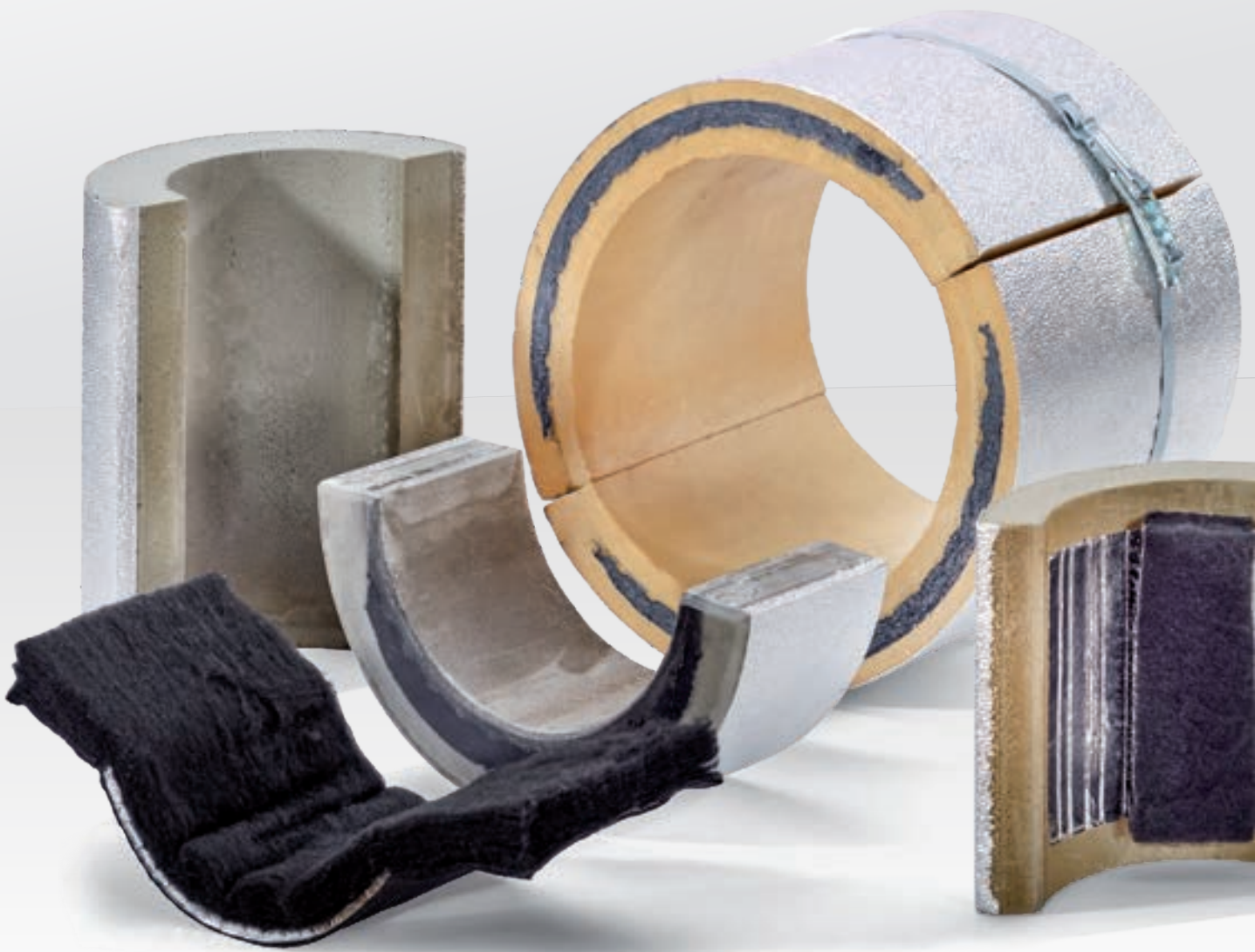

Systems

- Insulation systems with integrated Vacuum Insulation Panels
- Easy and quick to install
- Retrofitting possible
- Size and shape can be customised



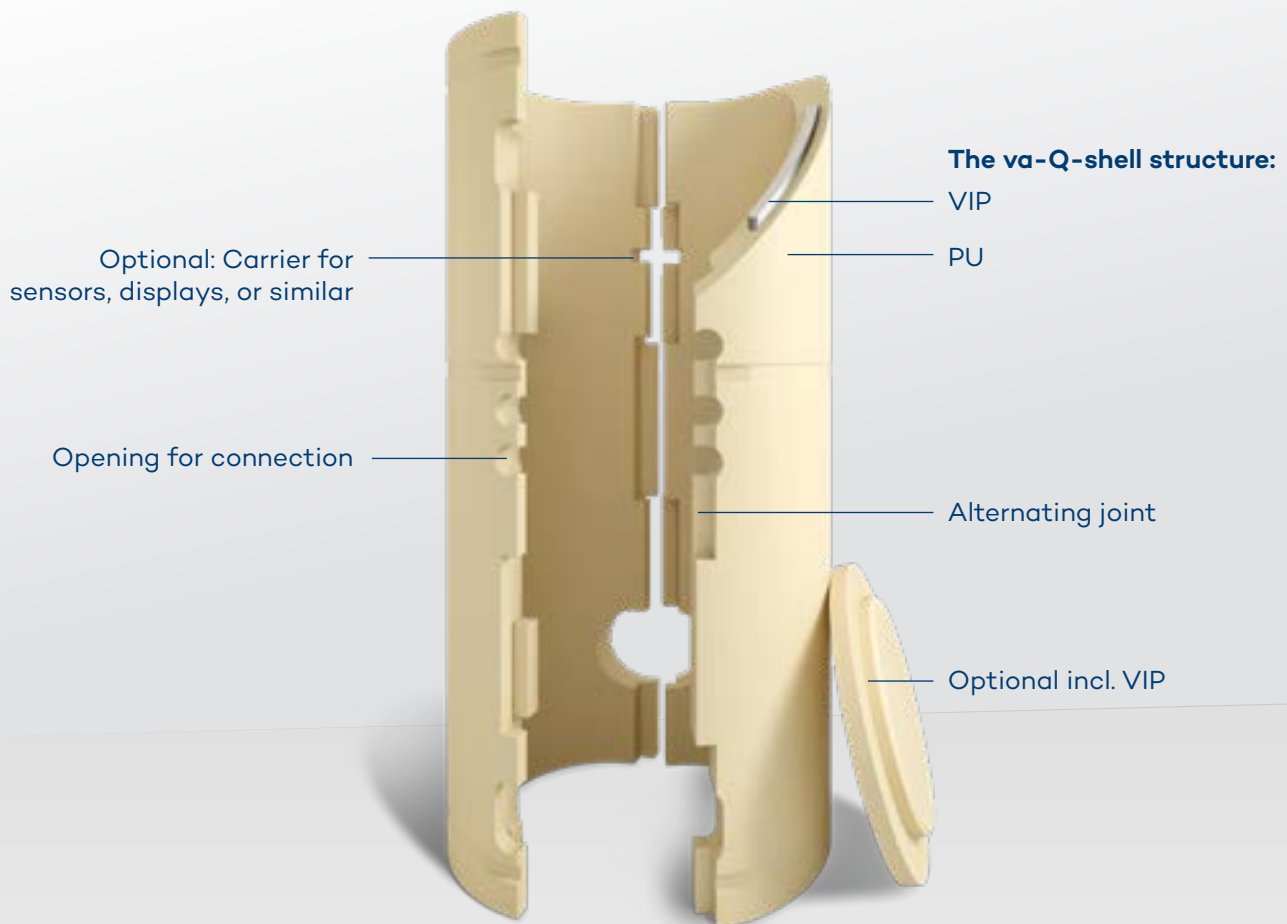

↖ ↗ **Product dimensions:** Height up to 3,000 mm
↙ ↘ (other sizes on request) **Diameter up to 2,000 mm**
Thickness/wall thickness up to 200 mm

- **Customer-specific solution**
- **Tongue-and-groove system for easy, quick installation**
- **No structural changes to the tank or changes in the production process necessary**
- **Excellent insulation performance for obtaining the A or A+ label**

va-Q-shell is a high-performance, easy to install insulation system for heat storage tanks with a good energy efficiency label. It essentially consists of one or more Vacuum Insulation Panels that are encapsulated in a polyurethane shell. The parts of the shell are joined together using an innovative tongue-and-groove system to ensure perfect seating and convective decoupling of the tank from its environment. Each va-Q-shell is individually adapted to the related tank size and shape and has cut-outs for pipes and inspection connections, as well as sockets sensors, displays, etc.

va-Q-shell pipe®

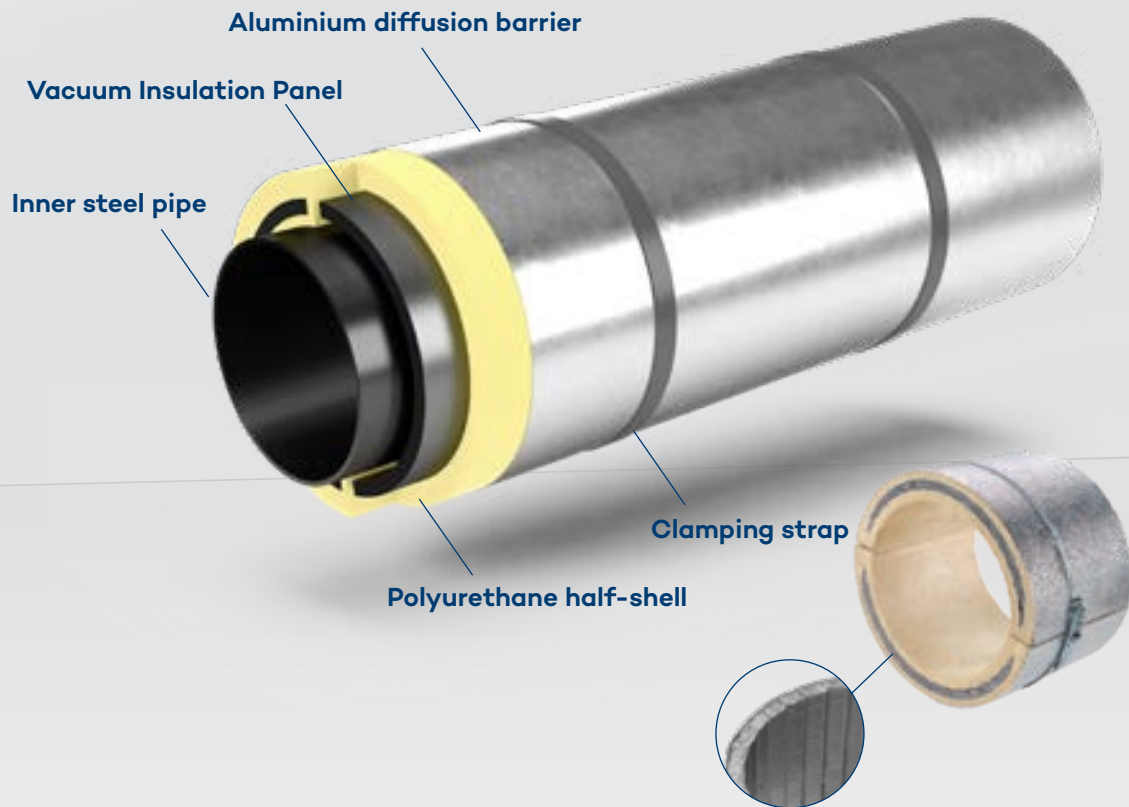

↖ ↗ **Product dimensions:** Length 1,000 mm (standard component)
↙ ↘ (other sizes on request) **For pipes with nominal diameters DN50 - DN200**
Thickness/wall thickness 40 - 100 mm

- **Super insulation with ultra-thin insulation at the same time**
- **Major reduction in the energy loss (up to more than 50%)**
- **Plug-and-Play system solution, also for upgrading**
- **Available for almost every pipe diameter and different types of pipes**

va-Q-shell pipe is an adaptation of the va-Q-shell insulation system for heating and cooling systems with nominal diameters of DN50 / 2" or larger. It consists of Vacuum Insulation Panels integrated into two polyurethane half-shells. va-Q-shell pipe can be easily installed using straps during the installation of the pipe-work. As standard the outer diameter of va-Q-shell pipe is covered with a layer of aluminium for mechanical protection and as a diffusion barrier. Various outer and inner layers are available on request.





Engineering support

- Comprehensive support for our customers from the concept to series production
- 20 years of comprehensive experience and know-how
- Quality assurance measures reflect highest quality standards



Technical service

As a service-orientated business, it is our aim to provide complete support to our customers' projects.

Our service includes:

- **Individual system solutions:** Due to our broad spectrum of components and production processes, our system solutions are individually matched to your requirements.
- **Continuous support:** from the initial analysis, through prototypes to economically viable series production applications, we accompany you during the entire development and production cycle.
- **More know-how:** based on the technical know-how of our specialists, we have a profound understanding of all thermal requirements and can offer an optimal service accordingly.
- **Comprehensive advice:** we simulate thermal systems and provide comprehensive thermal analyses and calculations to qualify or survey your applications.
- **More flexibility:** it is not only our products that are very flexible, our engineering is as well.
- **Innovations:** we analyse market and sector trends on a large scale, as well as specific customer requirements. If the perfect solution does not exist, we attempt to develop it.



The requirements on high-tech thermal insulation systems are numerous. Our expert team from the Thermal Engineering Center will help you to find the most cost-effective solution for your requirements. Here you profit from our many years of experience in the implementation of high-performance insulation. Along with first-class service and sound technical advice, we only produce products of the highest quality.

We are proud of our 20-years of experience and prize-winning technology. Dr. Roland Caps, Co-Founder



Our support for your product develop

To develop and implement the best solution for our customers, we support you from the initial project inquiry through to implementation and provide monitoring during series production.

For this purpose we have bundled our many years of experience in our Thermal Engineering Center to provide support to our customers during every development phase.

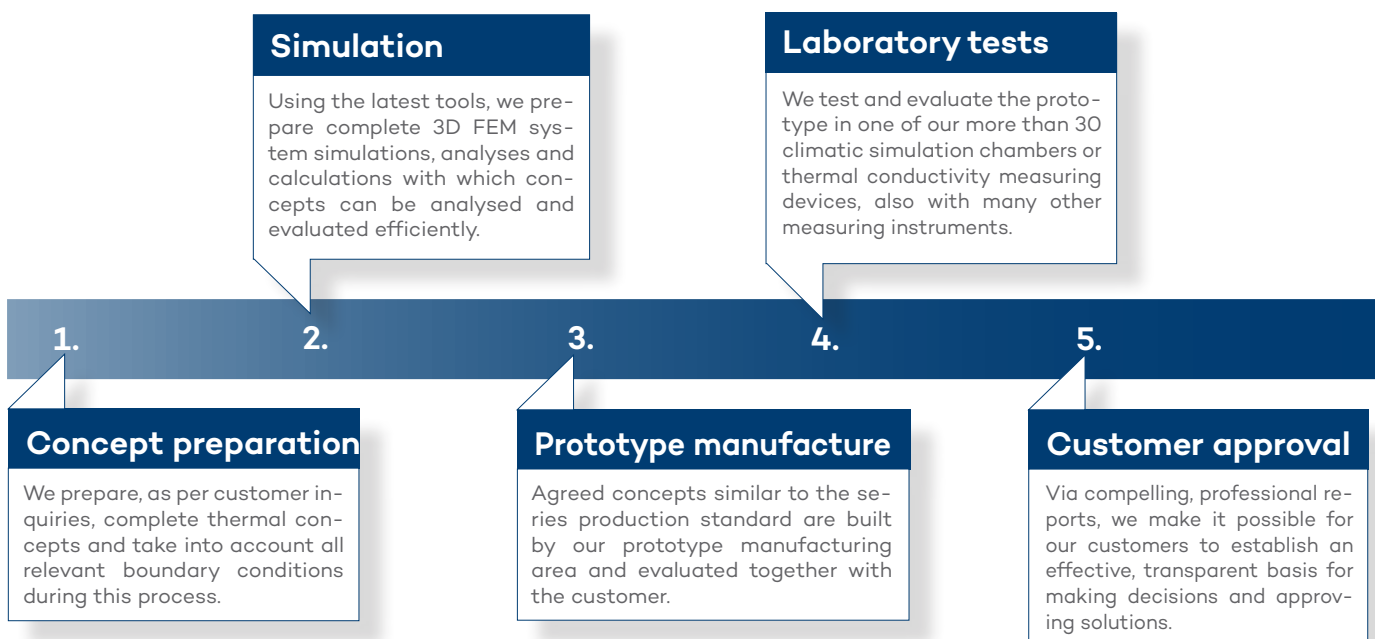



ment

Optimization

Detailed theoretical and practical analyses make it possible to identify potential for improvement at an early stage and to allow it to flow into the product.

6.

Initial sample testing

Initial sample tests agreed with the customer are undertaken based on the pre-production series. We send comprehensive documentation to our customers with the initial samples.

8.

Series production support

We are also there for our customers after series production start so that improvements can flow into the product or into the production.

10.

Qualification

Before the final start of series production, highly professional qualification measurements in accordance with the corresponding international standards can be undertaken using our comprehensive laboratory capacity.

7.

SOP

We also support the start of series production on-site at the customer and ensure, e.g. by means of our patented va-Q-check® measuring system, that there are no problems with our solutions.

9.



Our quality management

For quality assurance, we have implemented a comprehensive quality management system. This system ranges from component selection, through validation, to the continuous monitoring of our manufacturing processes and their documentation. In this way all components relevant for function are inspected before processing and approved; the quality of the semi-finished products is also checked during the ongoing processes. All products are subject to strict and to some extent 100% outgoing inspection that ensures full thermal insulation performance. Components are explicitly selected and our products subjected to realistic, long-term tests to meet the requirements of a market segment convincingly and sustainably.

Quality starts with the components...

For the hot water sector, we utilise, e.g., specially developed high-barrier foils for operating temperatures of up to 100 °C (short-term even higher) which are subjected to long-term tests on our test stands. The core material based on silica represents the second key component, we also continuously check the quality here. By means of our many years of experience, we ensure the components match the related application. If, e.g., glass fibres are used instead of silica in the high-temperature area, the thermal insulation performance will rapidly degrade. Due to the pore size in the core material and the resulting average free path length of the gas molecules diffused into the material, glass-fibre-based VIPs insulate worse than silica-based after just one month. After approx. 10 years, glass-fibre-based VIPs have lost their vacuum insulation performance almost entirely, while silica-based VIPs are still at an excellent approx. 7 mW/(m*K).





...extends through the consultation and manufacturing process...

Our Thermal Engineering Center accompanies you from thermal conception, through prototyping as well as thermal measurements, to series production implementation. Along with inspections during production, each VIP is checked with our unique va-Q-check® before shipment. During this inspection the internal pressure in the panel is checked in seconds. In this way va-Q-tec ensures the thermal performance of every single Vacuum Insulation Panel.

...to the customer!

Furthermore, we share our comprehensive experience and know-how with our customers. This support makes possible efficient implementation in the ongoing production process directly on-site.





Applications

- Hot water tanks
- Laboratory equipment and ultra-low temperature deep freezers
- Pipes
- Special applications





Hot water tanks

The importance of the protection of the environment and the climate has grown rapidly in recent years. Approaches and solutions to stop global warming are more important than ever. The biggest challenge is to satisfy increasing energy demand and nevertheless establish sustainable solutions.

Our approach is to save energy by means of extremely efficient thermal insulation solutions. By using Vacuum Insulation Panels, we can reduce the energy consumption of hot water tanks by more than 50%.

In industrialised countries, the portion of primary energy required for thermal processes is more than 55%, which means that the largest part of the energy demand is used for the generation of heat. In private households this figure is actually 75% due to heating systems and hot water heating, for example.

In the field of heating systems and hot water tanks, the effect of efficient thermal insulation is therefore particularly high. The energy efficiency label was introduced by the European Union in this context.

The energy label indicates the thermal losses of the system in operation and assigns them a label that transparently depicts the sustainability and environmental performance for the end customer.

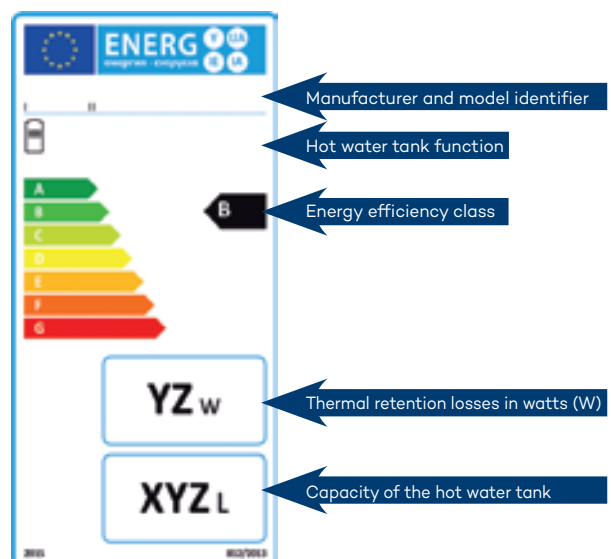



With our highly efficient, high-performance thermal insulation solutions for the heating industry, we make it possible for our customers to offer sustainable solutions. The application areas are very varied and our insulation solutions can be applied to small boilers, heat pumps, combination storage tanks, buffer tanks, seasonal tanks and special tanks (PCM, special shapes).

Available solutions:

Vacuum Insulation Panels (va-Q-vip, va-Q-plus, va-Q-pro) are attached directly to the tank, then encased in polyurethane foam and in this way applied to the product as insulation. (See page 12-15)

Our system solutions (va-Q-shell, va-Q-shell flex, va-Q-patch) are mature thermal insulation systems and are applied as complete insulation or as additional insulation under the conventional insulation on the product. (See pages 18-21)



Highest energy efficiency



Extraordinary cost-efficiency



Quality and very long product service life



Best ecolabel, quicker return on investment due to low energy costs



Very positive eco-balance



Extremely space-saving solution

Success story VIESSMANN

Successful partnership with VIESSMANN

Already in 2014, more than a year before the introduction of the first stage of the Ecodesign Directive ErP for heating systems and components, the successful co-operation between VIESSMANN SAS in Faulquemont and va-Q-tec AG from Würzburg started. The primary focus was not only on the usage of highly efficient VIPs, but also on a design that is as effective as possible and on an efficient integration into the production process. By means of the usage of VIPs, VIESSMANN was able to successfully position quality hot water tanks on the market, initially in the highest energy efficiency class A and later also in A+. Not only was the portfolio expanded in this way, together an important contribution was also made to the topic of energy efficiency.

Vitocell 300-V

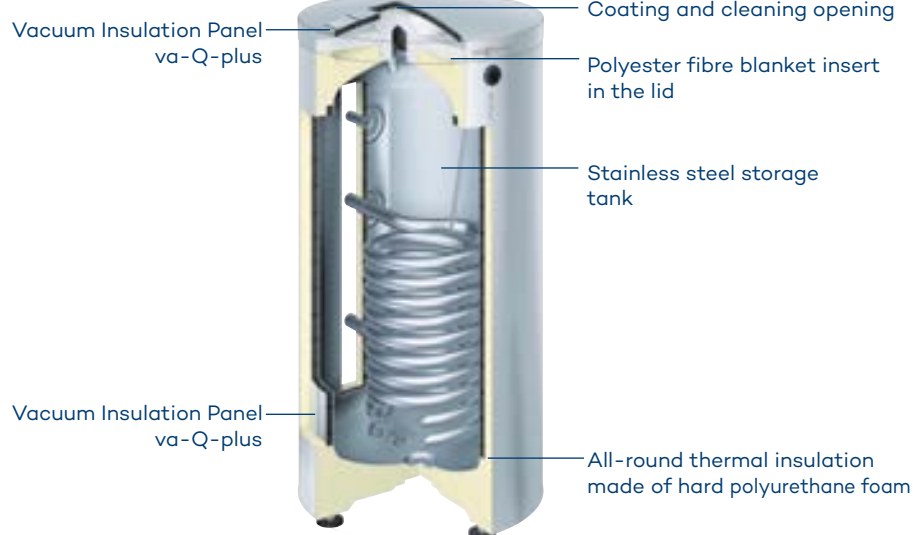

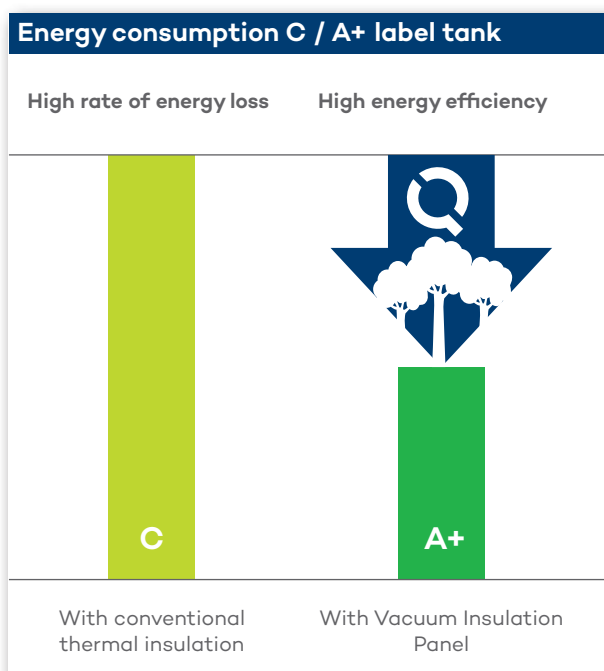

A 300 litre tank with the efficiency label C has, e.g., a power loss of approx. 85 W, while the same tank with an A+ label has a power loss of less than 36 W. That is more than 50% less or a saving of more than 1 kWh per day.



Our system solutions

Since the tightening of the requirements and the expansion of the Ecodesign Directive ErP in September 2017, the energy label has been expanded to tanks above 500 litres. As such these tank sizes must also be correspondingly efficiently insulated to obtain a good label at the A or A+ level.

There are two challenges:

1. For larger tanks it is relatively more difficult to obtain an A or even A+ label compared with smaller tanks. For this reason, thermal insulation must be correspondingly thicker or more efficient for these tanks.

2. The tanks are already so large even without thermal insulation that they can only be installed without thermal insulation. The insulation must then be applied separately after installation. It is exactly here that the three va-Q-tec solutions are applicable. va-Q-shell and va-Q-shell flex as well as va-Q-patch make it possible for the installer to fit, also on-site, reliable, slender and highly efficient thermal insulation to the buffer tank.

Products compared	va-Q-shell	va-Q-flex	va-Q-patch
Insulation performance	✓✓	✓	✓
Flexibility	○	✓✓	✓✓
Investment	✓	✓	✓✓
Tool costs	○	✓✓	✓✓
Wall thickness of complete system	✓✓	✓	✓
Features	✓✓	✓	○
Combination with polyester blanket insulation	N/A	✓	✓



Makes possible energy efficiency label A/A+



Cost-efficient solution



Easy and quick installation

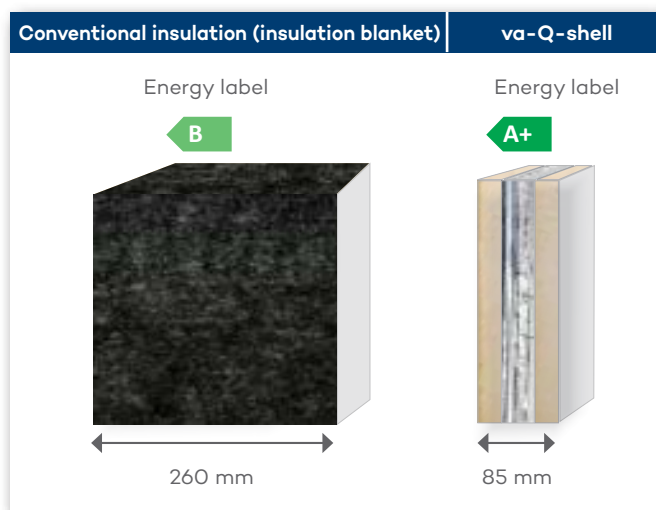

There are significant grants available from the authorities for energy-efficient tank solutions, also for renovation projects.



Success story: BINDER

About BINDER

BINDER is the leading specialist for scientific and industrial laboratories and is focussed entirely on the related simulation cabinets. Several thousand such appliances leave the works in Tuttlingen each year. The brand image is characterised by cutting-edge technology, innovations and absolute precision.

Challenge

The continuous internal temperature of approx. $-86\text{ }^{\circ}\text{C}$ requires high energy usage. Standard insulating materials are thick and occupy valuable internal space or contribute to an increased total volume.

Solution

By means of the use of VIPs on all six sides, thinner walls are made possible and the energy consumption reduced at the same time. In this way no condensation forms on the outer casing.



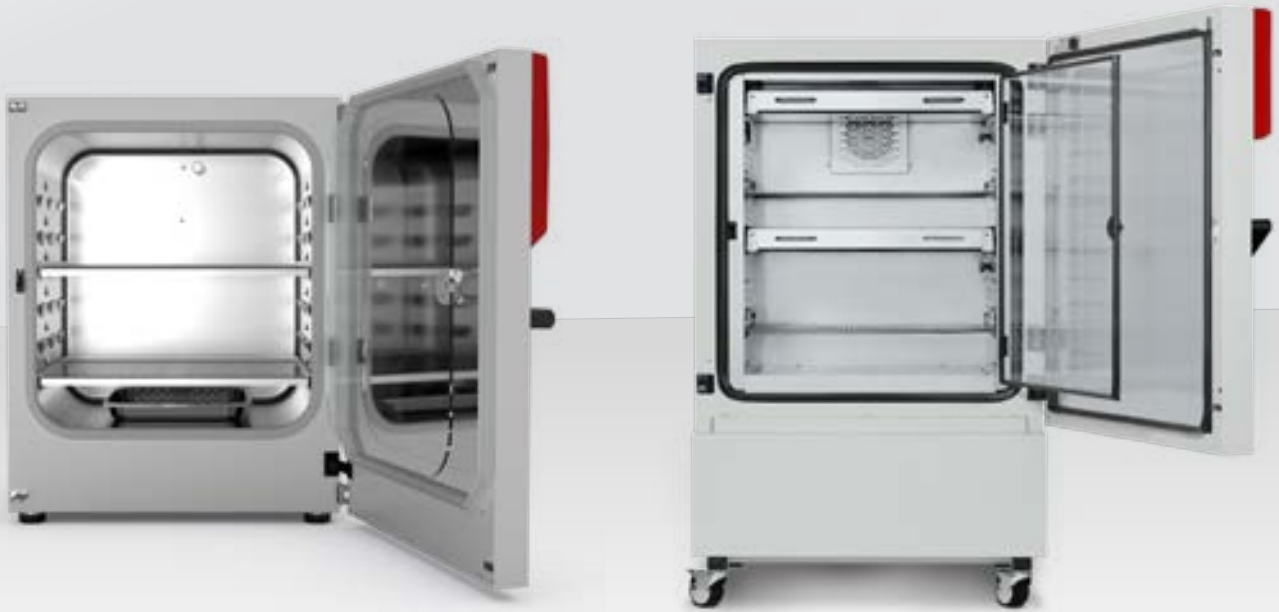

Support during Corona vaccine research

Along with support to global, life-saving medicine logistics for Corona test kits and vaccines, with its unique Vacuum Insulation Panels (VIPs) va-Q-tec is also supporting the German laboratory equipment manufacturer BINDER; BINDER's equipment is considered imperative for Corona research. In this way va-Q-tec is actively contributing to fighting the virus also in this area.

va-Q-tec AG has collaborated with BINDER GmbH for many years. However, in times of the Corona crisis, the system relevance of this co-operation has become clear: to find a suitable vaccine or remedy for the pathogen, the pathogen must be produced synthetically. The breakthrough in the synthetic reproduction of the virus was achieved by a research team at the University of Bern (Switzerland) with the aid of BINDER ultra-low temperature deep freezers.

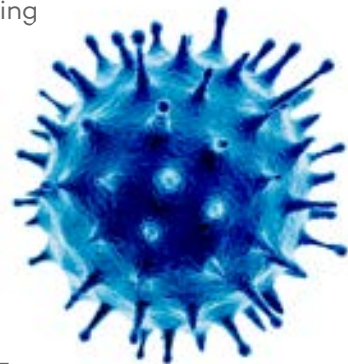

These laboratory appliances must sustainably and reliably maintain temperatures lower than $-86\text{ }^{\circ}\text{C}$. These temperature retention characteristics can be guaranteed by fitting va-Q-tec's VIPs in an energy and cost-efficient manner. Due to the ten-times better insulation than conventional insulating materials, the panels make it possible to manufacture freezers with thinner walls. As a consequence the internal volume of the appliance increases and more samples can be placed in it.



Piping

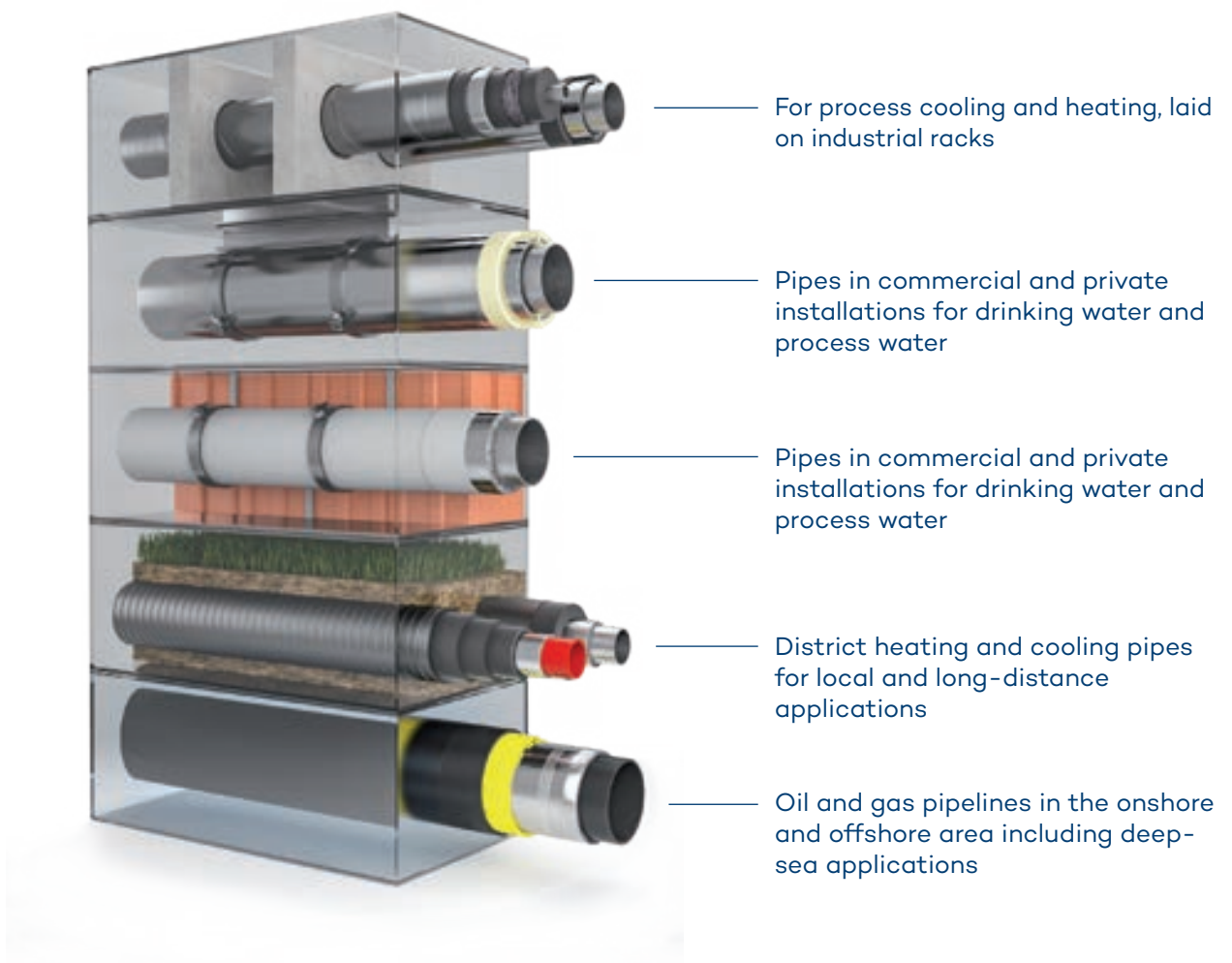



Cold and heat are transported via pipes in countless different applications worldwide. This transport takes place over both long distances of many kilometres and also over short distances in technical appliances and plants. In conventionally insulated pipes, this transport either involves high energy losses or thick insulating materials must be used.

We offer a large range of highly efficient thermal insulation solutions for many applications and pipes of almost all types. The basis for these system solutions is formed by the related VIPs with their low thermal conductance figures. These panels are integrated into an overall solution that meets the varying geometric, thermal and technical requirements for the related type of application.

Together, all these system solutions have excellent thermal insulation performance but nevertheless thin insulation. In this way the power losses can be reduced by up to 50% or even more compared with conventional pipe systems. The slender structure also means less space is required on-site. As a complete system, valuable time can also be saved during installation.

Our customers therefore sustainably save energy, space, time and costs.



Cost-efficient solution



Reduction of the energy consumption and the CO₂ emissions



Thinner insulation creates more usable space



Durable and manufactured to the highest quality standards, "Made in Germany"

Piping applications

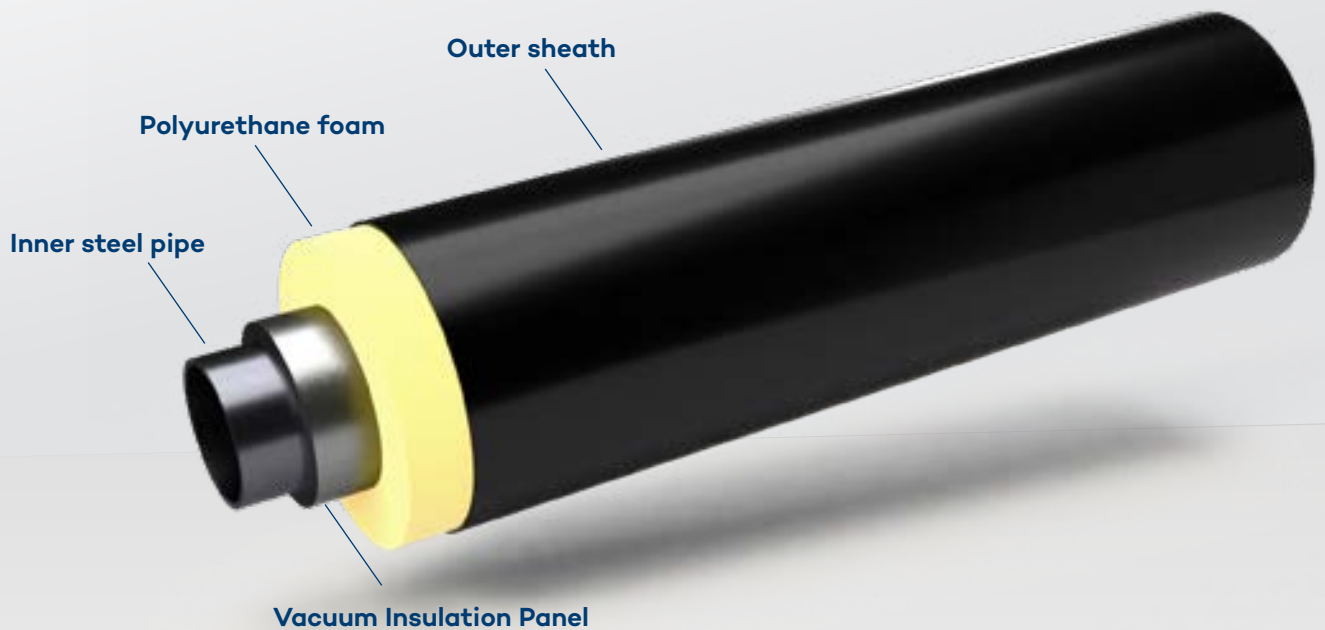

Application: Steel district heating pipe.

Purpose: Extremely high efficiency for long pipe runs.

The challenge: In the area of district heating and district cooling, fluid is transported over long distances. Due to the thermal losses of the standard insulating materials, as a rule polyurethane foam, only a fraction of the energy arrives at the user.

Our solution: By means of the combination of the standard thermal insulating materials with our high-performance VIPs, the losses described above can be reduced by 50% or even more. As a consequence the thermal losses are reduced in the extreme and more energy reaches the users.

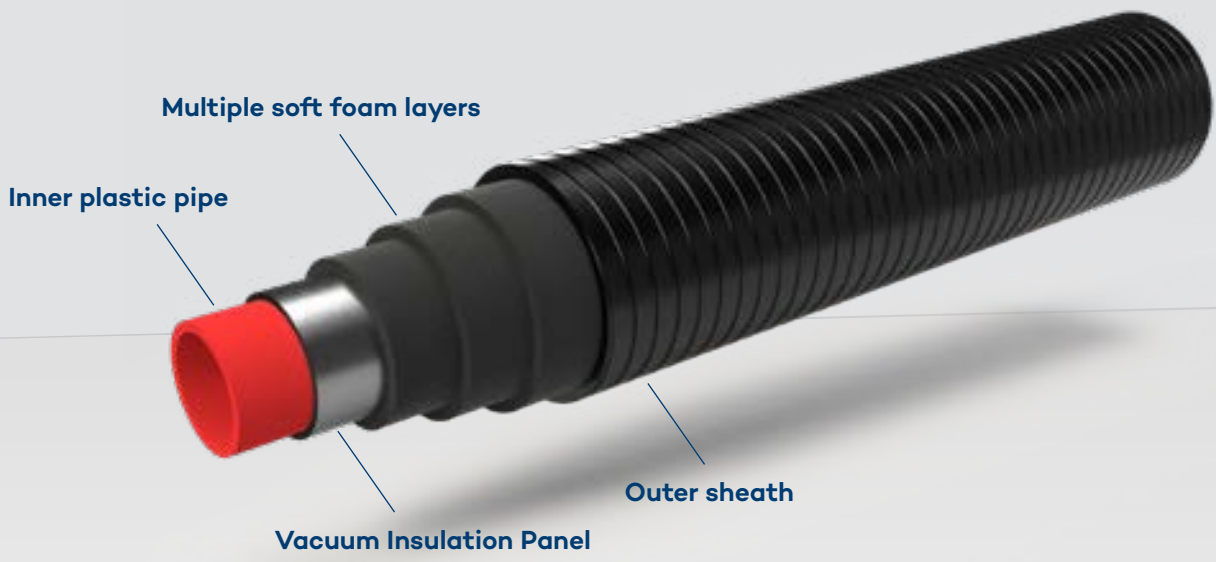

Application: Plastic district heating pipe.

Purpose: Energy efficiency combined with high pipe flexibility.

The challenge: In local district heating and cooling networks, pre-insulated pipe systems, with almost rigid polyurethane foam insulation or with more flexible polyethylene foam insulation, are often used. During the selection of the pipe system, it is therefore necessary to decide for lower thermal losses (PU foam) or higher flexibility (PE foam).

Our solution: By means of the combination of the standard thermal insulating materials with our high-performance VIPs, flexibility, ease of installation and energy saving can be obtained with a simultaneous diameter reduction.

Piping applications

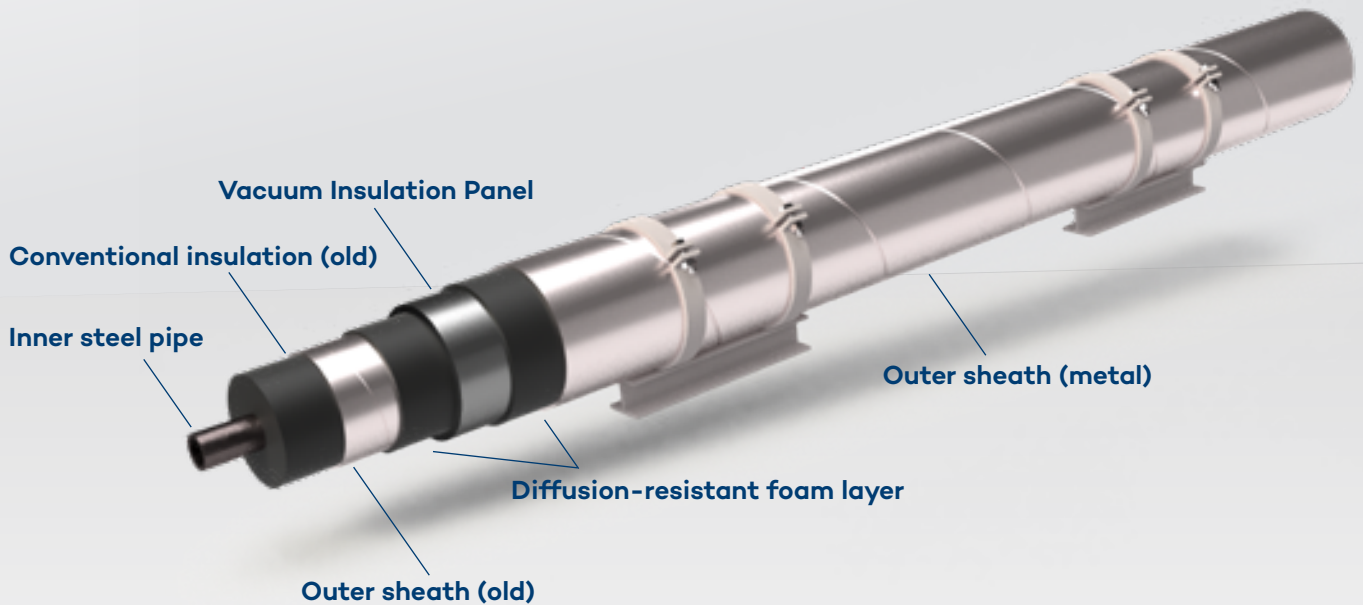

Application: Upgraded low-temperature pipe.

Purpose: Upgrading existing or faulty insulation with highly efficient VIPs.

The challenge: For pipes already installed, the failure of conventional insulating materials can result in enormous energy losses, damage due to corrosion, as well as degradation of safety (e.g. formation of ice due to condensation).

Our solution: The excellent compatibility of our high-performance VIPs with conventional insulating materials results in a quick, straightforward repair to the existing insulation, without the need to remove the existing insulation. Reliable operation compliant with health and safety regulations can therefore be continued straightforwardly.

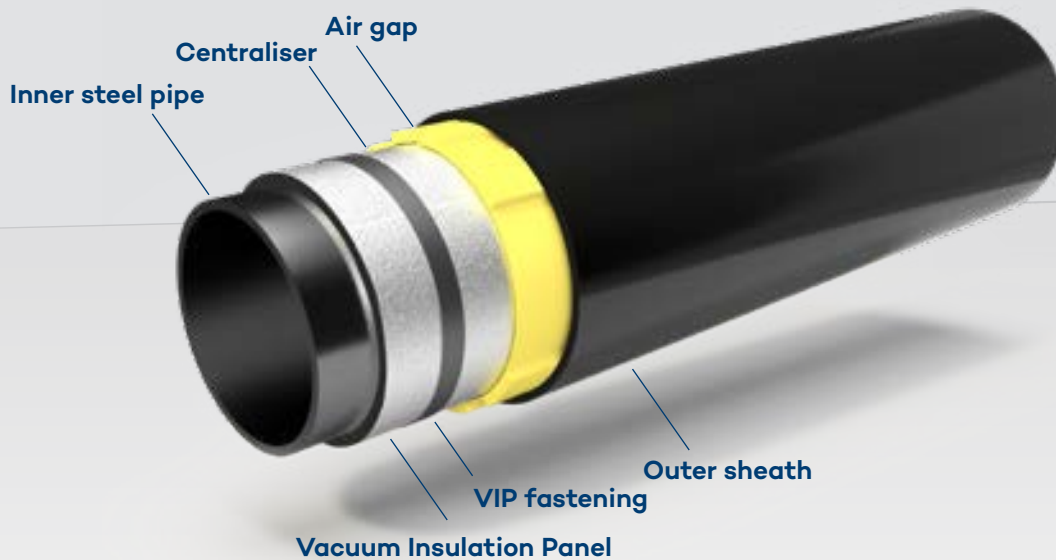

- Application:** Pipe in pipe solution for long-distance onshore & offshore pipes.
- Purpose:** Prevention of hardening and blockage by means of highly energy-efficient VIPs.
- The challenge:** To be able to pump and transport fossil fuels reliably, blocking of the pipe during operation must be prevented. In addition, quick and trouble-free installation of the insulation and laying of the pipe must be ensured.
- Our solution:** By using high-performance VIPs, the thermal requirements in relation to the operating temperature can be met. At the same time, the external diameter of the pipe system can be reduced to a minimum, in this way material costs are saved and logistic advantages obtained.

Piping applications

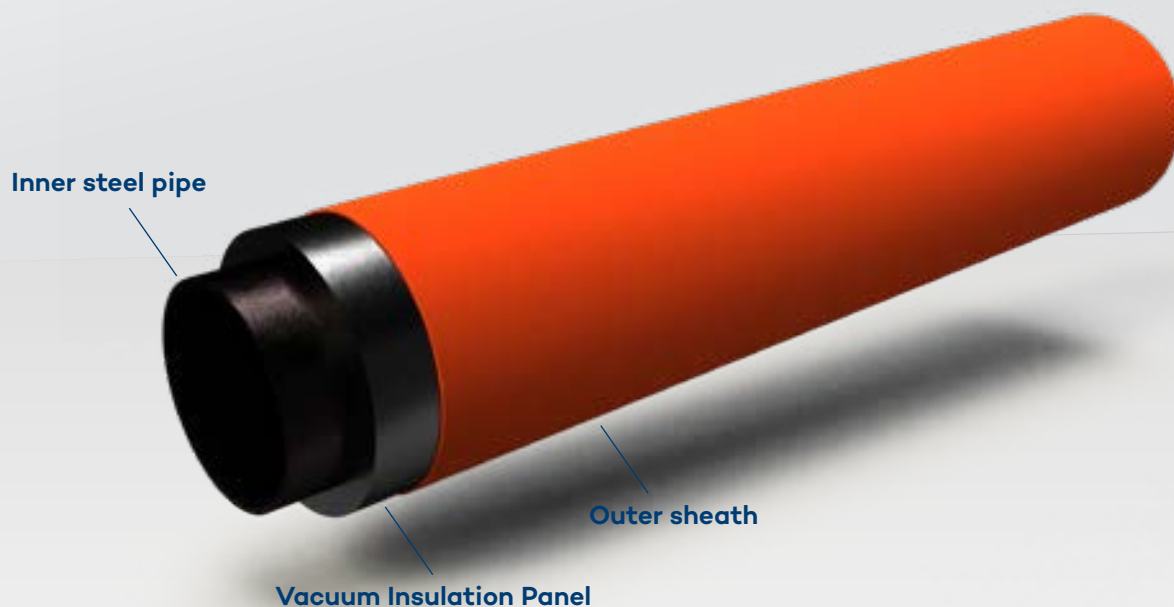

Application: Drinking water supply for public buildings. Insulation system – can be used directly on-site.

Purpose: Prevention of the formation of legionella by means of highly efficient insulation.

The challenge: Due to long pipe runs (among others in public buildings), it is often a challenge to maintain the corresponding drinking water quality. There is a risk of the formation of bacteria if drinking water pipes are heated or cooled.

Our solution: By means of the use of our high-performance VIPs, even in tight installation ducts with neighbouring pipes which can affect the temperature, the space required for the insulation is reduced to a minimum. At the same time, the heating or cooling of the pipes with water is slower meaning that active cooling units and/or circulation lines do not need to be used.

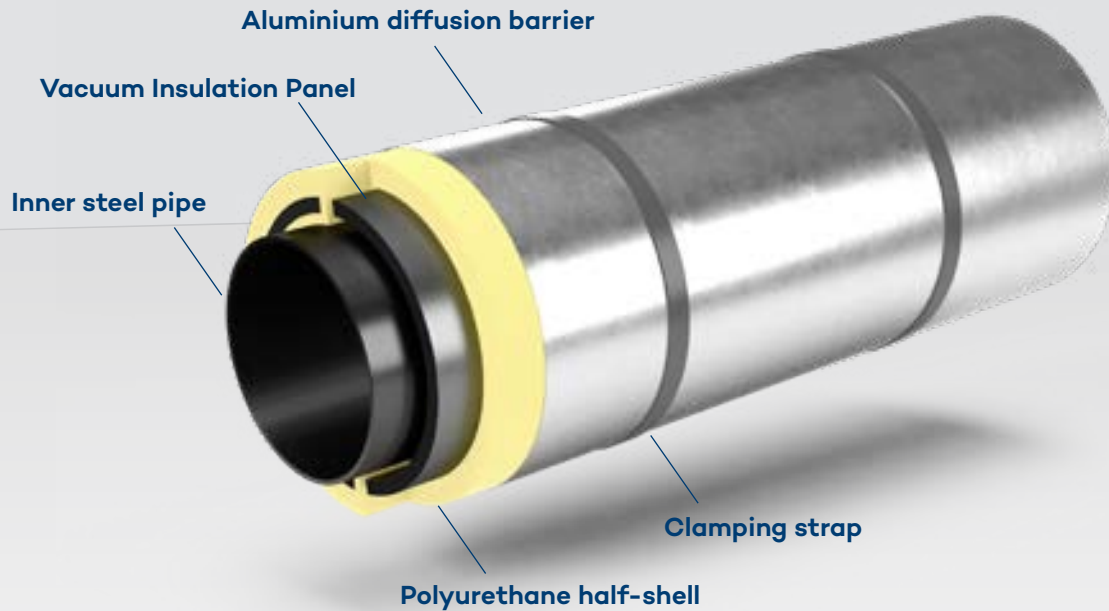

Application: Insulation system – can be used directly on-site.

Purpose: Half-shells for uninsulated components and for upgrading.

The challenge: In plant engineering and in industrial processes, a good insulating effect, quick processing as well as thermal process reliability must be ensured in a small space. Conventional insulating materials often reach their limits while attempting to meet these criteria.

Our solution: va-Q-shell pipe, as a system solution, offers the perfect insulation for pipes that are to be insulated after installation. The combination of va-Q-tec's high-performance VIPs with polyurethane foam insulation makes it possible to meet energy standards (e.g. the German energy saving ordinance (EnEV), VDI 4610, etc.) while at the same time reducing the thickness of the insulation by up to 50%. va-Q-shell pipe is available in almost all common pipe diameters and is easy to install. Individual extra features for your project can be taken into account on request.



Special applications

Project: thermally insulating softshell accessories for the FARO FocusS and FocusM series: scanning in extreme temperature conditions

The new FARO thermal protection softshell was developed with the objective of stabilising the temperature of the FocusS or FocusM scanner for operation in extreme environmental conditions, i.e. high atmospheric temperatures of up to + 55 °C and strong, direct sunlight.

Note: in direct sunlight (equator regions) the solar heating can be up to 1.3 kW/m². The softshell accessory is designed to prevent rapid overheating of the measuring instrument. Integrated into a light, robust softshell design, the FARO thermal protection combines functional elements for effective shielding of the instruments against the absorption of IR radiation, effective high-performance insulation against the excessive entry of heat and heat absorber for the effective dissipation of excess energy from the instrument.



With this construction, vacuum insulation elements of type va-Q-vip (which has a thermal coefficient of permeability approx. 10-times lower than polystyrene foam) adapted to the specific size play an important role by minimising the thermal transfer from the hot ambient atmosphere to the instrument. As was possible to confirm by means of intensive stress tests at FARO R & D and at selected customers who work under extreme conditions, the softshell thermal insulation makes it possible to **extend the operating time** of the laser scanner **by a factor of 4-6x** compared with operation without protection against the heat.



Project: insulation of company's BMW i3

With increasing electric mobility, it has been found that enormous range losses occur in a hot or a cold environment. This loss is due to power losses in the batteries as well as the need for their capacity for climatic comfort (heating and cooling). Our **VIPs improve battery performance, climatic comfort and range.**

This improvement has been demonstrated in an internal project during which we insulated a BMW i3 with our VIPs. Significant improvements were achieved in both the climatic comfort and in the driving range due to their thermal performance.

VIPs installed and their positions:

- **Total area of the VIPs: 5.94 m²**
- **9 different panels with a thickness of 10 mm (doors, roof and luggage compartment)**





Special applications

Project: ISS

Our VIPs are also on the International Space Station, ISS. Due to their excellent material characteristics, they were installed in an appliance for maintaining a constant temperature known as the "freezer / refrigerator / incubator" (for short: FRIDGE) to ensure **complete temperature control during special experiments** on the space station.





Project: cloud chamber

The cloud chamber is an extension of the large-scale research facility AIDA for experiments at the Karlsruhe Institute for Technology (KIT) related to climate research. The goal of the research is to investigate the effect of ice-forming aerosol particles on the climate, weather and environment and on the production of clouds and rain.

For this purpose, a cylindrical chamber with active wall cooling was developed; this chamber operates in the temperature range between -50 °C and $+30\text{ °C}$. Because **good temperature homogeneity** is important during cooling and at constant temperatures, the chamber was encased in **va-Q-tec insulation** to improve the temperature homogeneity.



Thermal Energy Efficiency Milestones

2001

Construction of the first VIP plant and start of series production.



2010

With va-Q-pro, the first flexible VIP is available. InPow technology is used for the first time in VIP-production.



2010

Use of VIP technology also in refrigerated vehicles: Krone presents the first VIP-insulated refrigerated trailer at the IAA Transportation.



2008

Start of production of va-Q-plus, which has an improved price-performance ratio. First VIPs with PowTec technology are delivered to the refrigeration industry.



2010

Thanks to the VIP-insulated battery, the Zephyr Project breaks the world record for continuous flight.



2014

First hot water tank with VIPs receives the Eco-Label A+. The product is presented to the public for the first time by VAILLANT at the ISH in the following year.



2016

va-Q-shell is presented: the first high-performance, easy-to-install insulation system solution for hot water tanks



2021

Market launch of va-Q-shield, the first VIP with extremely high fire protection: qualified for use in aircraft, certified with B1 classification for buildings.



2021

Innovation va-Q-steel: First VIP that provides excellent insulation at very low and high temperatures of up to up to +400 °C.

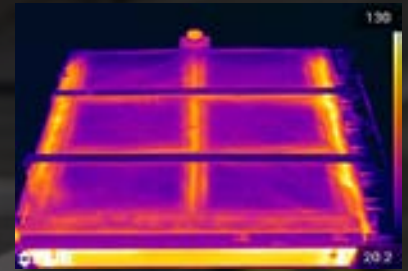

2014

VIP technology is also used for leisure applications: the first series deliveries are made.



2020

Market launch of va-Q-vip Floor, the first insulation system from va-Q-tec for flat roofs, balconies and terraces.



2021

va-Q-tec signs strategic partnerships in the Aviation & Automotive industry and in the field of pipeline construction.

First series deliveries for highly efficient district heating pipes.

 | HUTCHINSON®

uponor

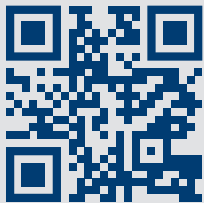

Do you have any questions or would you like to arrange an appointment with our expert in Switzerland?

Our sales partner **AGITEC AG** would be pleased to be of assistance:
+41 44 316 63 73 | info@agitec.ch | www.agitec.ch

 va-Q-tec.com  [@vaQtec](https://twitter.com/vaQtec)  [va-Q-tec](https://in.linkedin.com/company/va-Q-tec)  [va-Q-tec AG](https://www.youtube.com/va-Q-tec)

